

Assembly Instructions

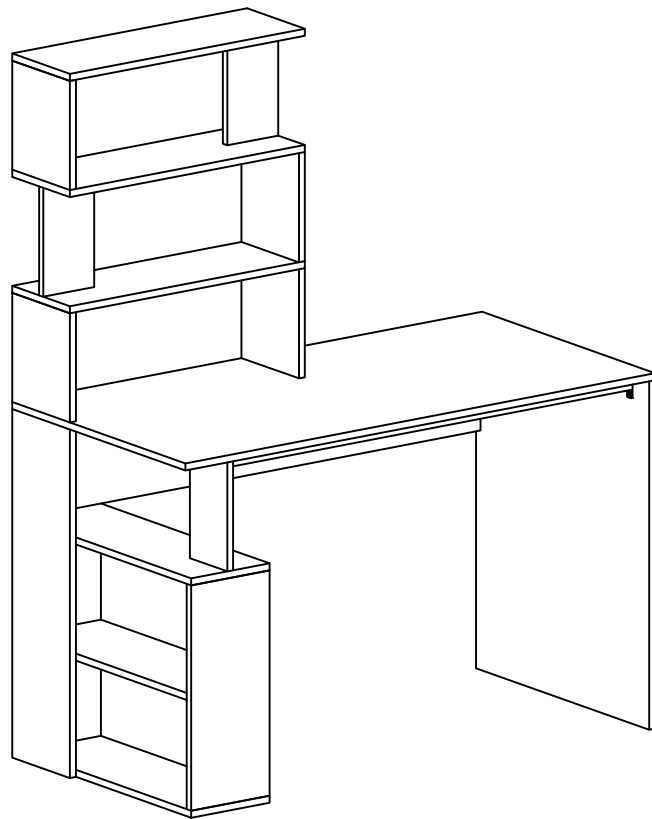

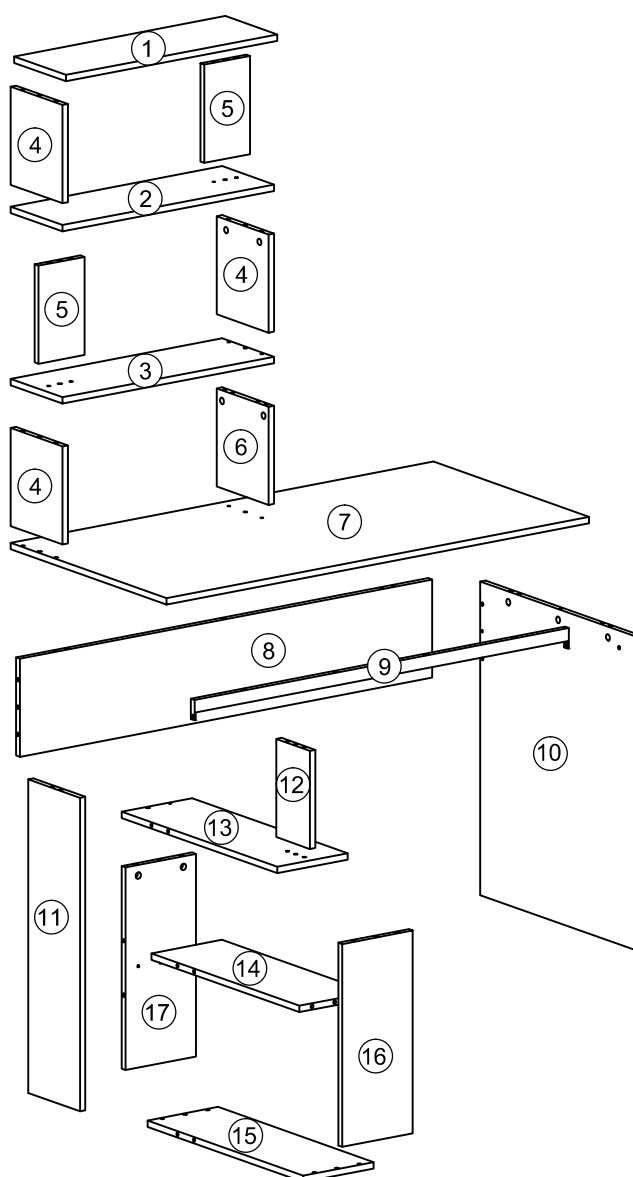



COMPONENTS ID Nr.

Part Nr.	Qty	Part Nr.	Qty	Part Nr.	Qty
①	1pcs	②	1pcs	③	1pcs
④	3pcs	⑤	2pcs	⑥	1pcs
⑦	1pcs	⑧	1pcs	⑨	1pcs
⑩	1pcs	⑪	1pcs	⑫	1pcs
⑬	1pcs	⑭	1pcs	⑮	1pcs
⑯	1pcs	⑰	1pcs		

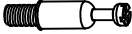

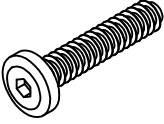
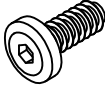
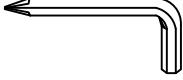

HARDWARE LIST

<p>A=38</p>  <p>M6*35mm</p>	<p>B=38</p>  <p>Ø15*11mm</p>	<p>C=32</p>  <p>Ø8*30mm</p>
<p>D=18</p>  <p>M6*48mm</p>	<p>E=4</p>  <p>M6x40mm</p>	<p>F=2</p>  <p>M6x12mm</p>
<p>G=1</p>  <p>M4</p>		



PRODUCT ASSEMBLY

1

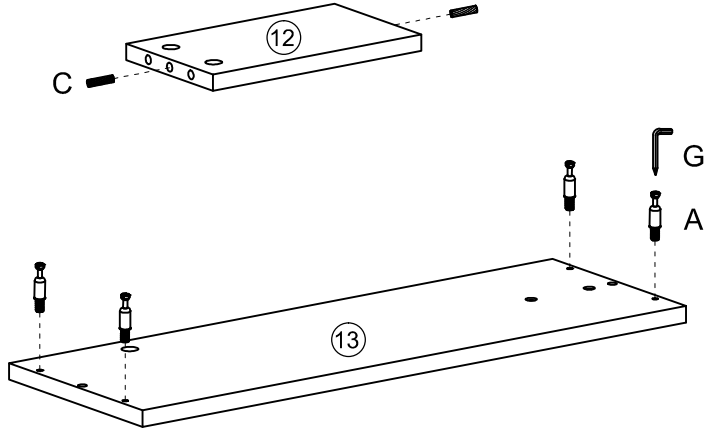
$\varnothing 8 \times 30 \text{mm}$  C x 2	M6*35mm  A x 4	M4  G	
---	---	---	--



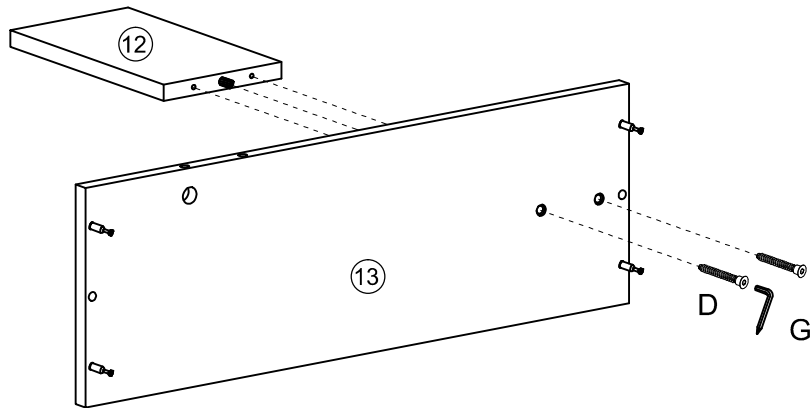

2

M6*48mm  D x 2	M4  G	
---	--	--



PRODUCT ASSEMBLY

3

$\varnothing 8*30\text{mm}$  C x 6	M6*35mm  A x 4	M4  G	
---	---	---	--

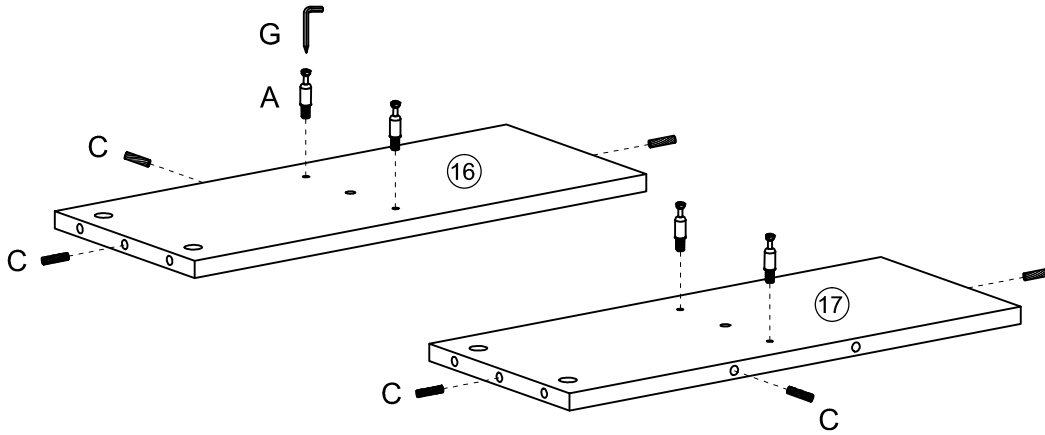

4

$\varnothing 8*30\text{mm}$  C x 3	
---	--

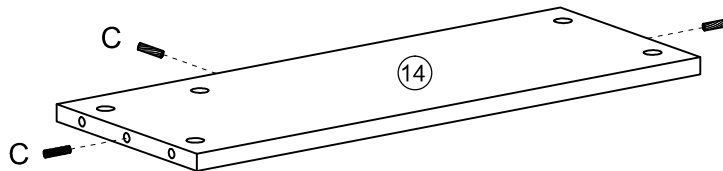

PRODUCT ASSEMBLY

5

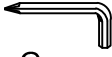
$\phi 15*11\text{mm}$  B x 4	M4  G	
---	--	--

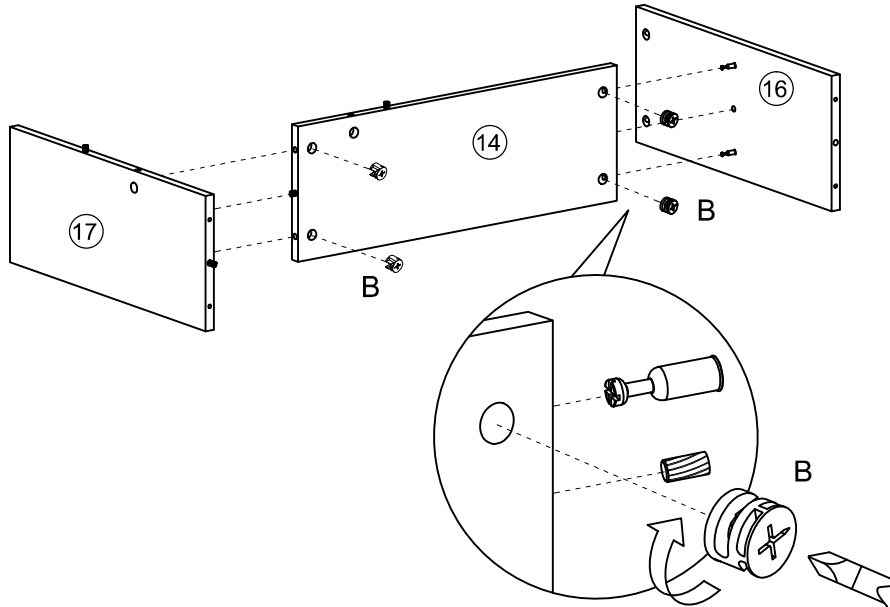

6

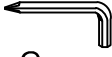
$\phi 15*11\text{mm}$  B x 4	M4  G	
---	--	--

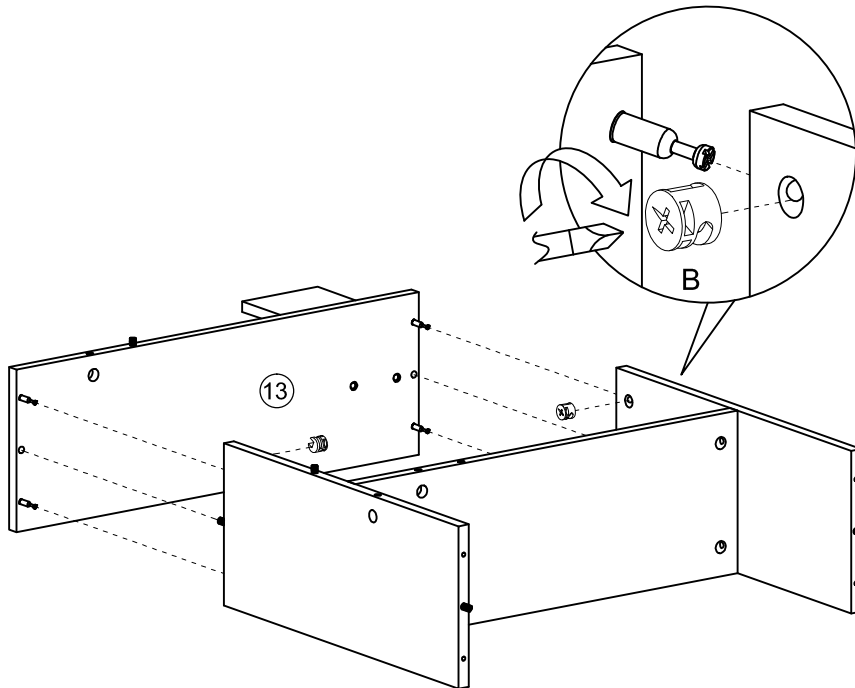



PRODUCT ASSEMBLY

7

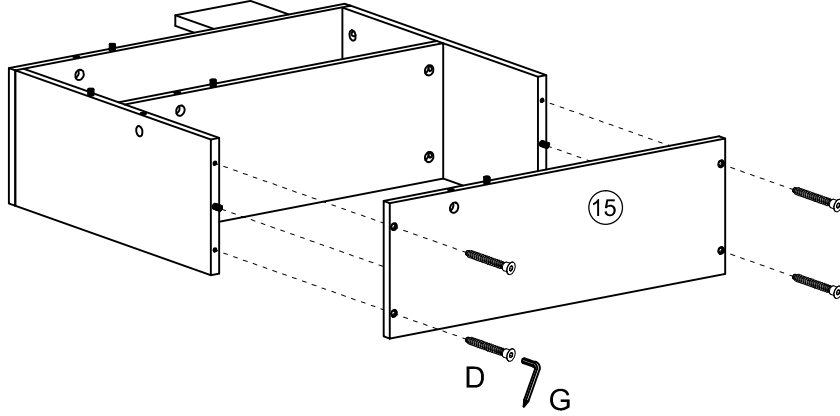
M6*48mm  D x 4	M4  G	
---	--	--



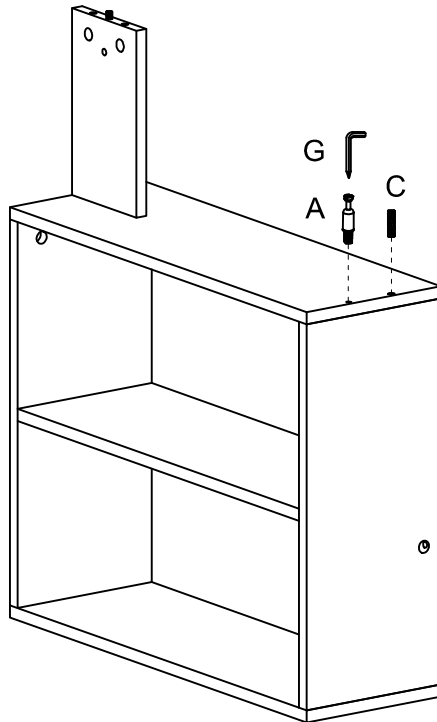

8

$\phi 8*30$ mm  C x 1	M6*35mm  A x 1	M4  G	
--	---	---	--





PRODUCT ASSEMBLY

9

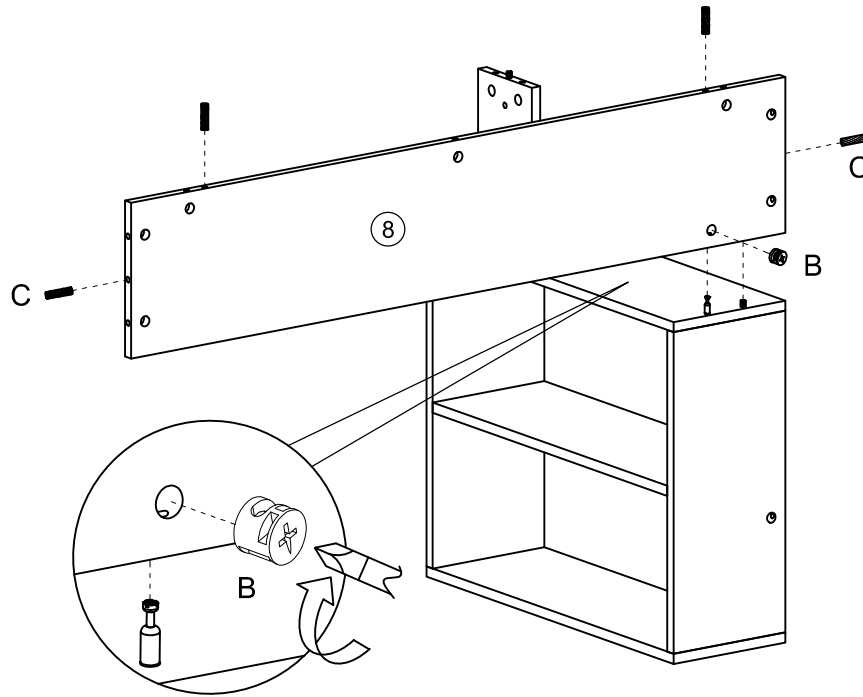
$\phi 8 \times 30 \text{mm}$  C x 4	$\phi 15 \times 11 \text{mm}$  B x 1	M4  G	
--	---	---	--



10

$\phi 8 \times 30 \text{mm}$  C x 3	M6*35mm  A x 8	M4  G	
--	---	---	--

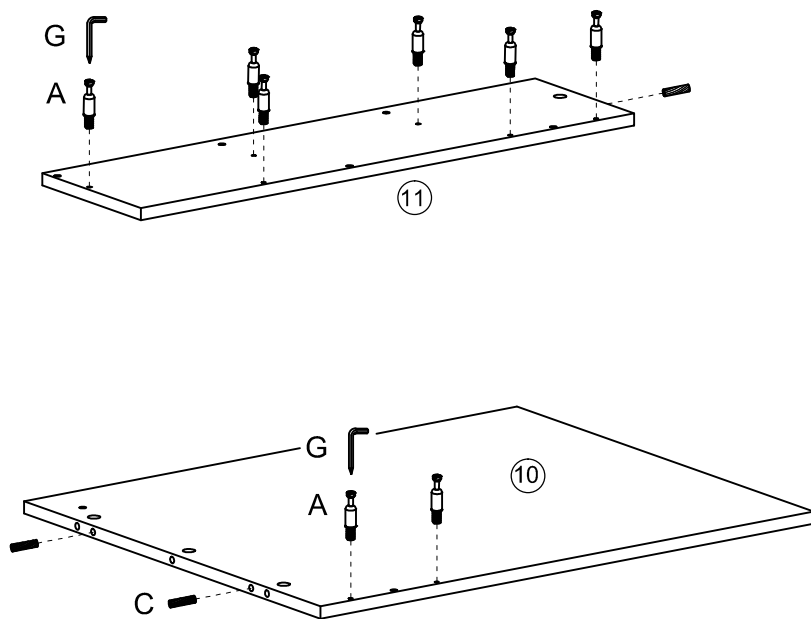

PRODUCT ASSEMBLY

11

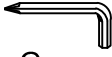
$\phi 15*11\text{mm}$  B x 6	M4  G	
---	--	--

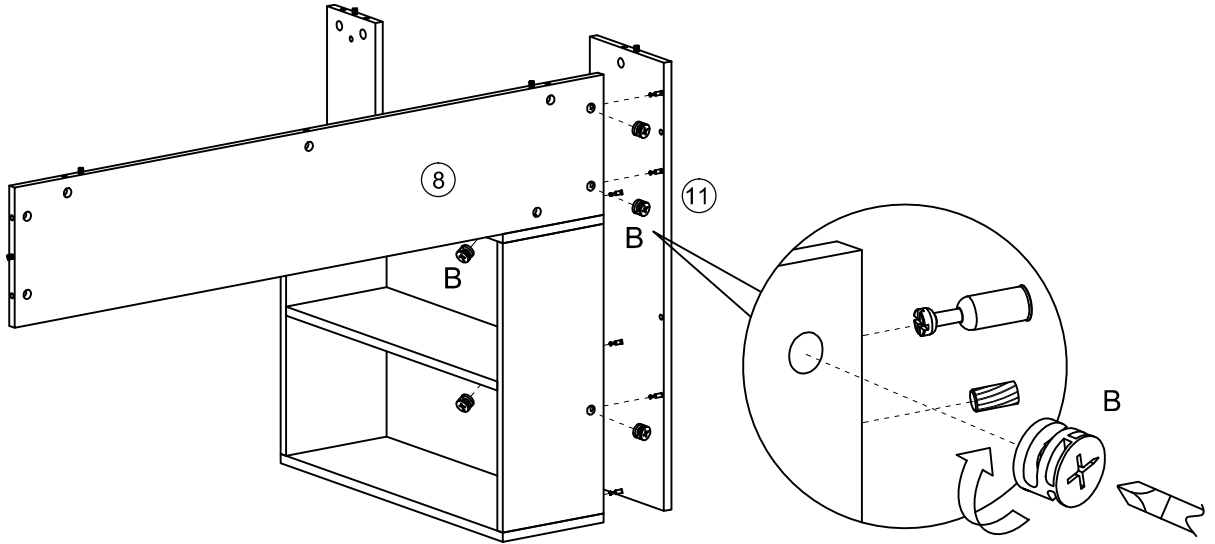

12

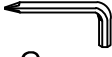
$\phi 15*11\text{mm}$  B x 2	M4  G	
---	--	--

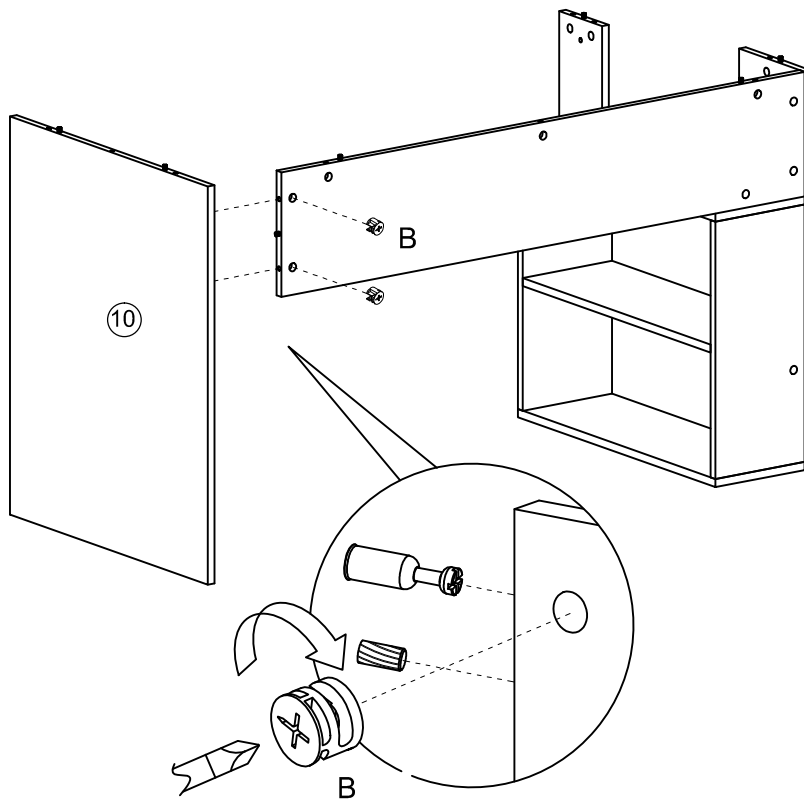

PRODUCT ASSEMBLY

13

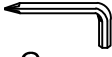
M6x12mm  F x 2	M4  G	
---	--	--

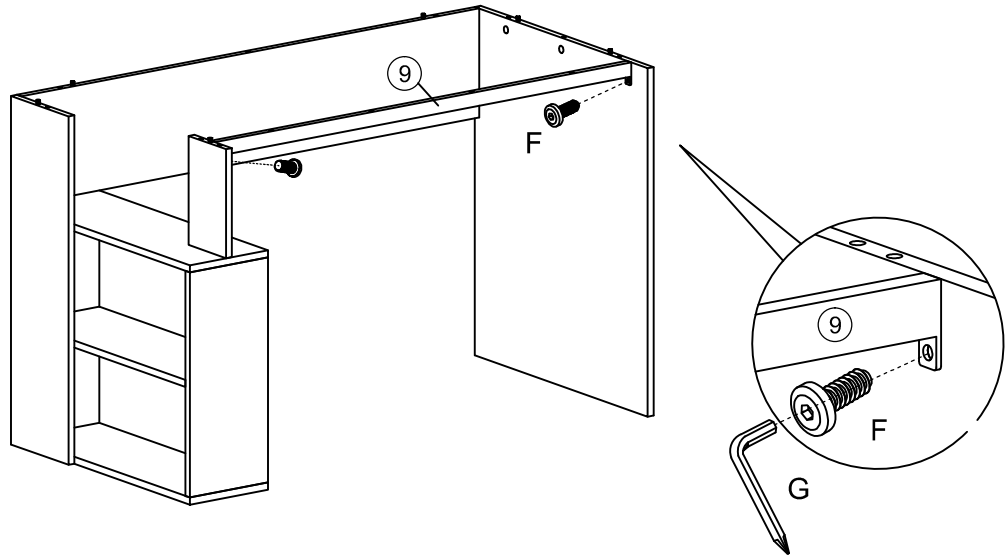

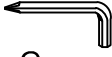

14

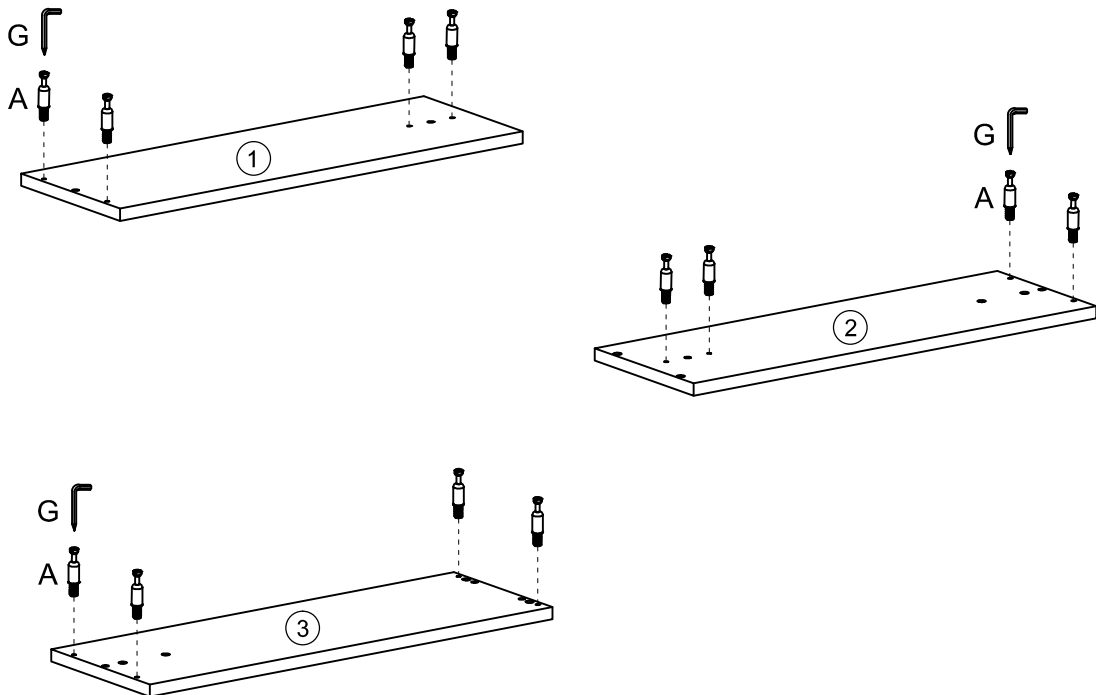
M6*35mm  A x 12	M4  G	
--	--	--





PRODUCT ASSEMBLY

15

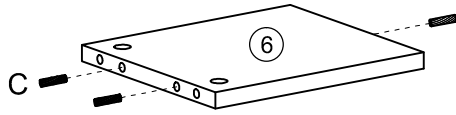
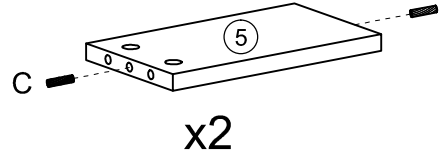
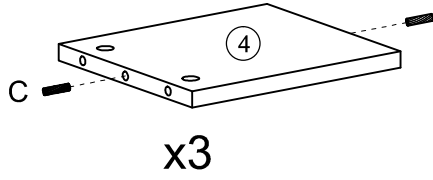
$\phi 8*30\text{mm}$  C x 13	M4  G	
---	--	--



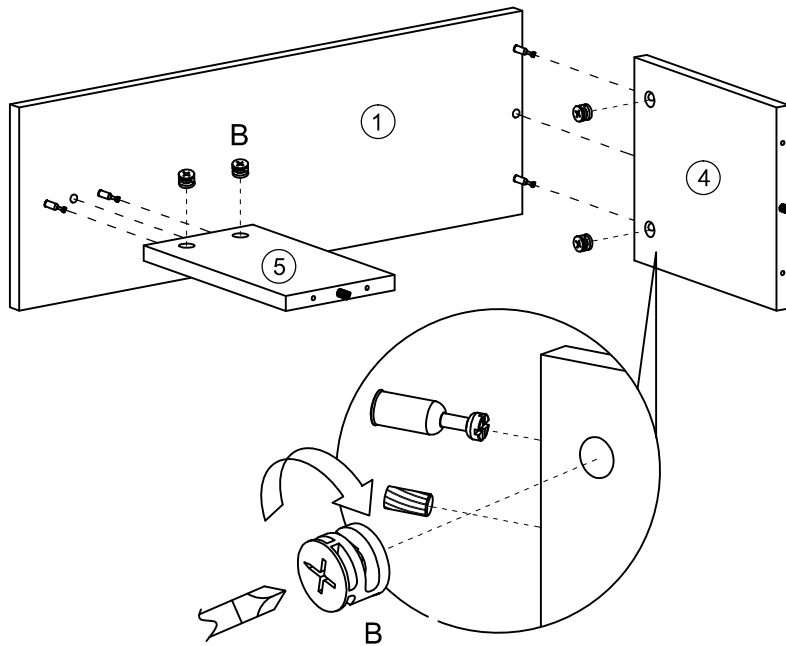

16

$\phi 15*11\text{mm}$  B x 4	M4  G	
---	--	--



PRODUCT ASSEMBLY

17

M6*48mm  D x 4	M4  G	
---	--	--

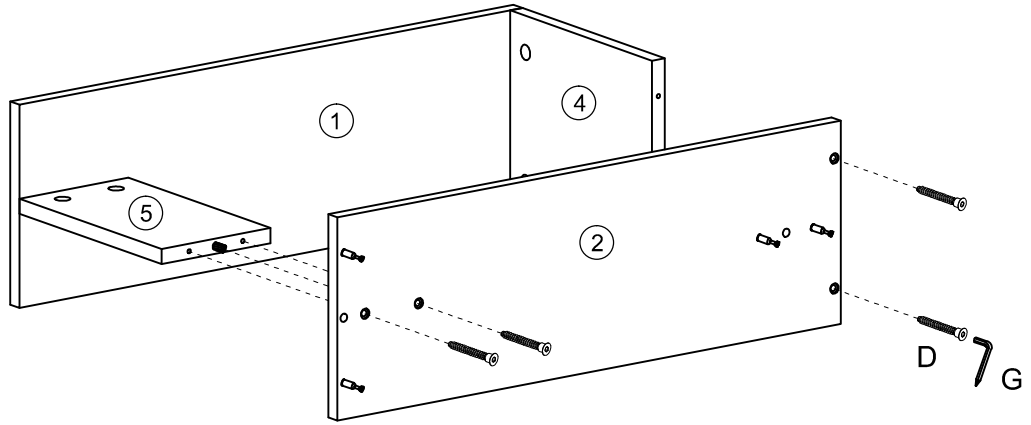

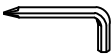

18

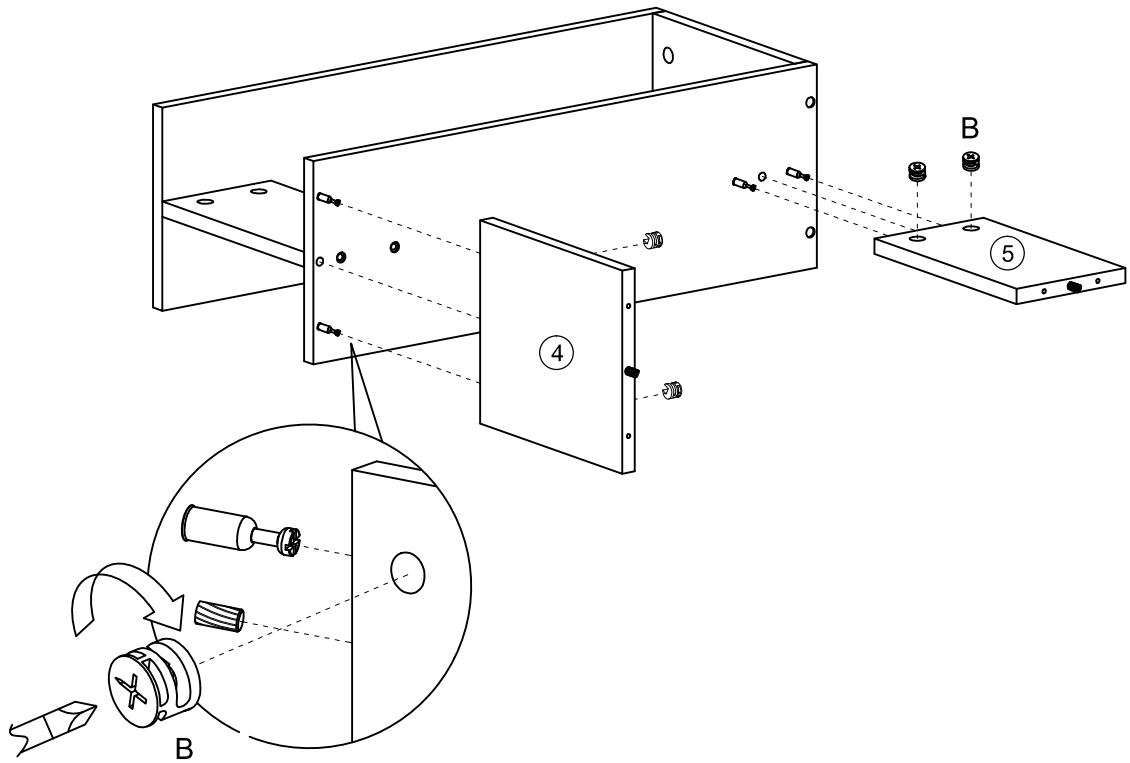
$\phi 15*11\text{mm}$  B x 4	M4  G	
---	--	--





PRODUCT ASSEMBLY

19

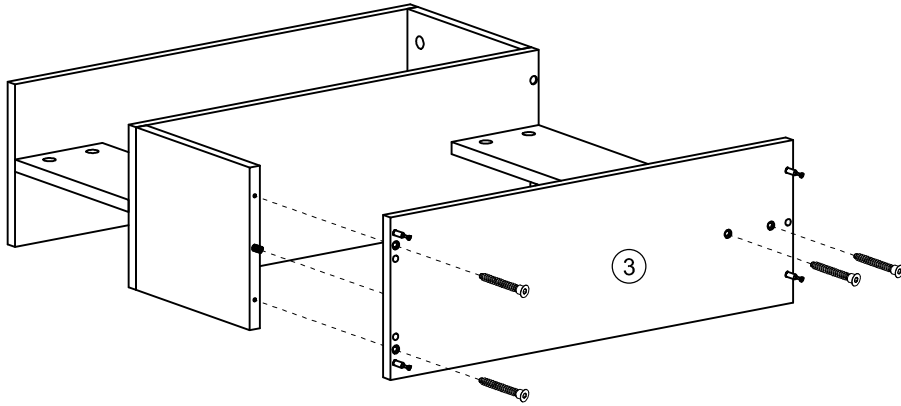
M6*48mm  D x 4	M4  G	
---	--	--



20

$\phi 15*11\text{mm}$  B x 4	M4  G	
---	--	--

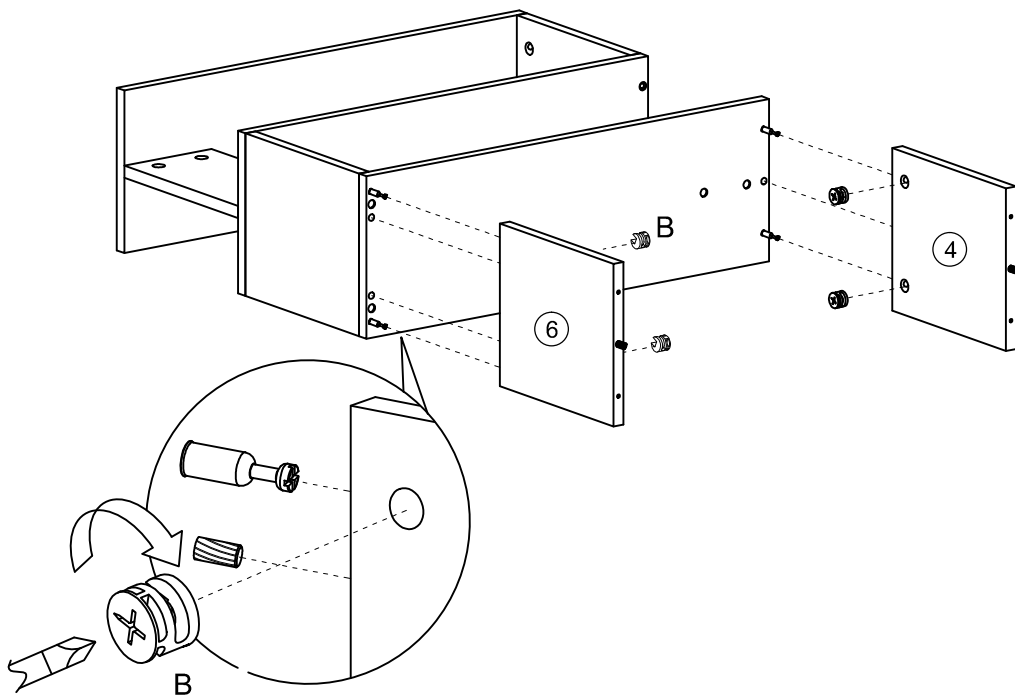

PRODUCT ASSEMBLY

21

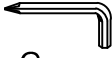
M6*35mm  A x 9	M4  G	
---	--	--

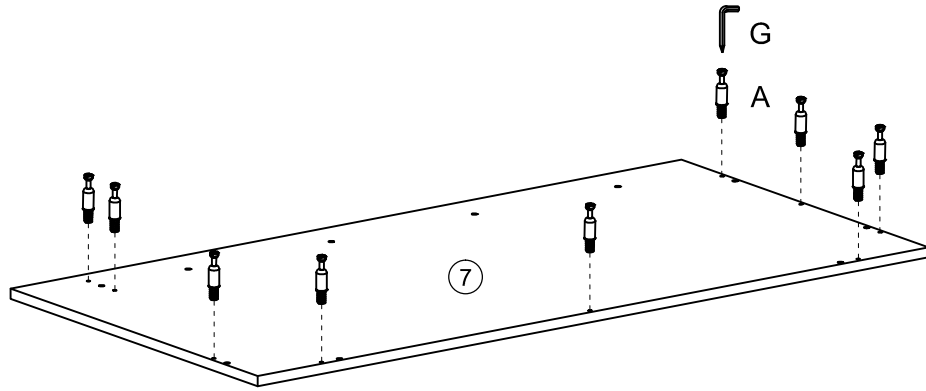

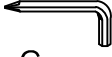

22

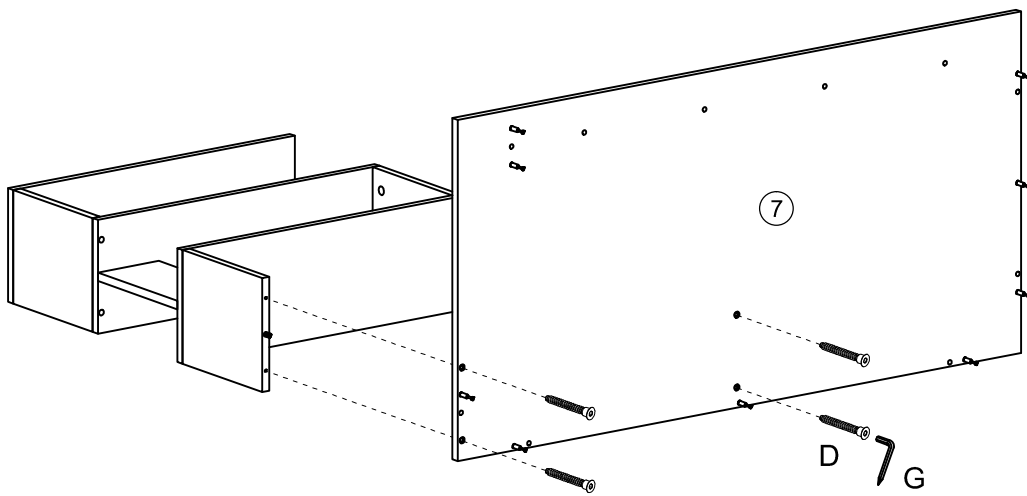
M6*48mm  D x 4	M4  G	
---	--	--

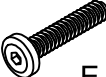

PRODUCT ASSEMBLY

23

$\phi 15 \times 11 \text{mm}$  B x 6	M6x40mm  E x 4	M4  G	
---	---	---	--

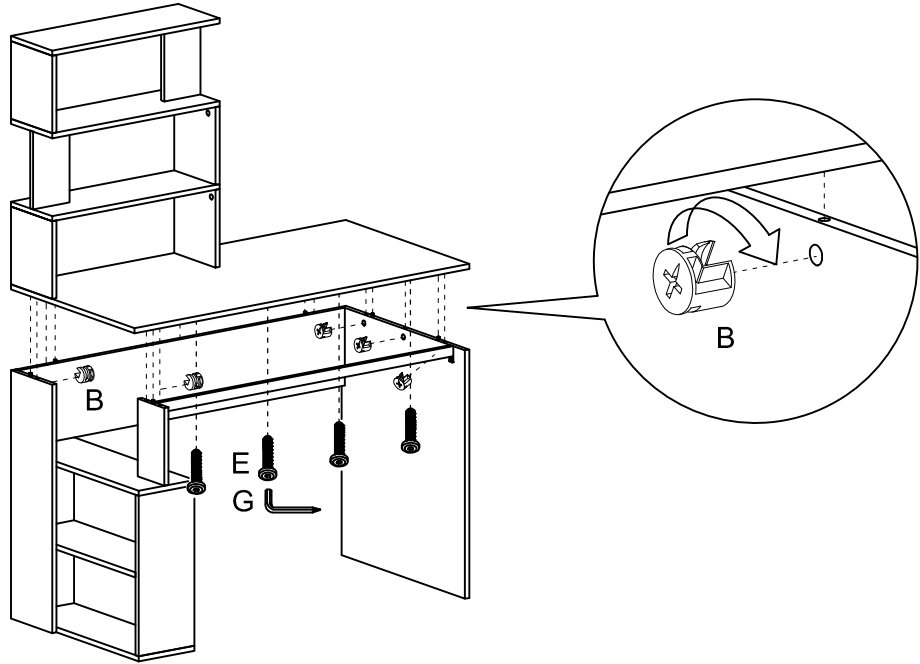

24

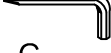
$\phi 15 \times 11 \text{mm}$  B x 3	M4  G	
---	--	--

