

ASSEMBLY INSTRUCTIONS

Important Safety Instructions:

- Please read all instructions before beginning assembly
- Please make sure receive all the parcels to start the assembly
- For your safety and convenience, assembly by two people is recommended
- Use the parts and hardware lists to identify and separate each of the components included
- Save all packing materials until assembly is completed to avoid the accidental discarding of smaller parts or hardware

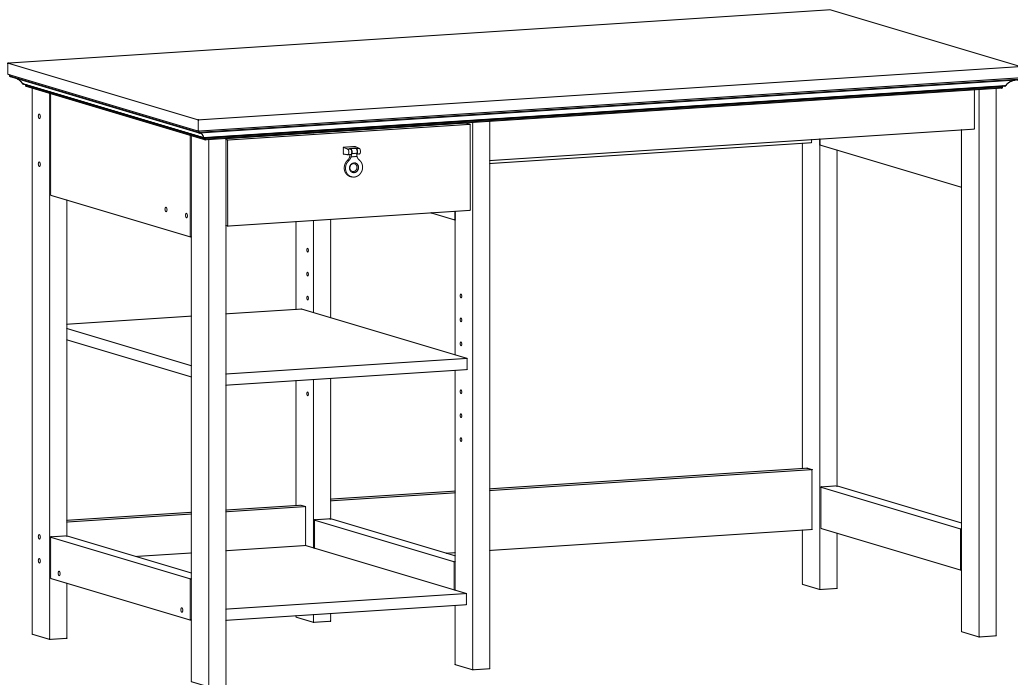

THANK YOU FOR PURCHASING

PARTS LIST

- | | | | | |
|-------|-------|-------|-------|-------|
| 1 X1 | 2 X1 | 3 X1 | 4 X1 | 5 X1 |
| 6 X1 | 7 X1 | 8 X1 | 9 X1 | 10 X1 |
| 11 X1 | 12 X1 | 14 X1 | 15 X1 | 16 X1 |
| 17 X1 | 18 X1 | | | |

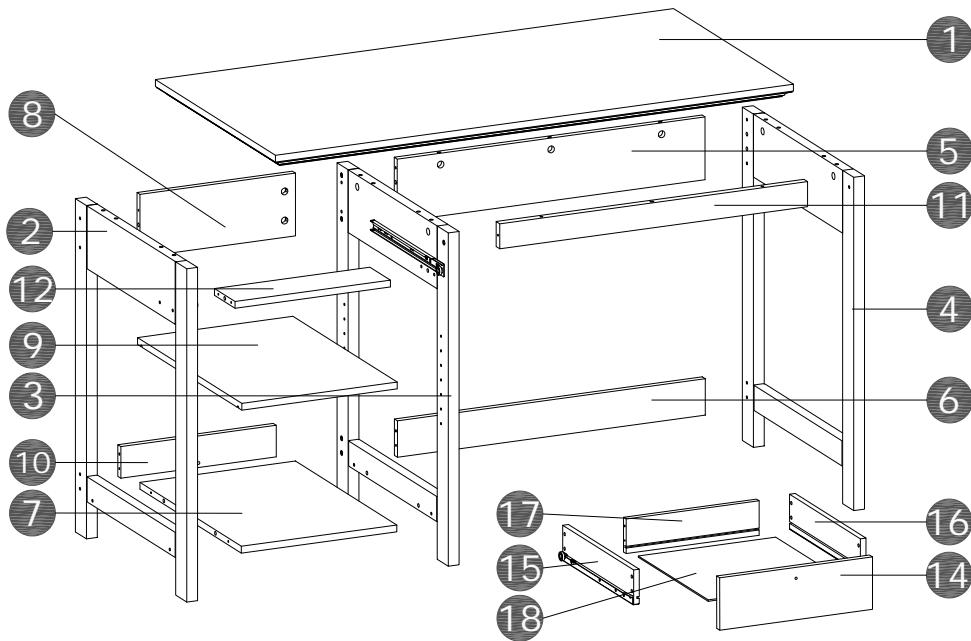

Maximum weight capacities



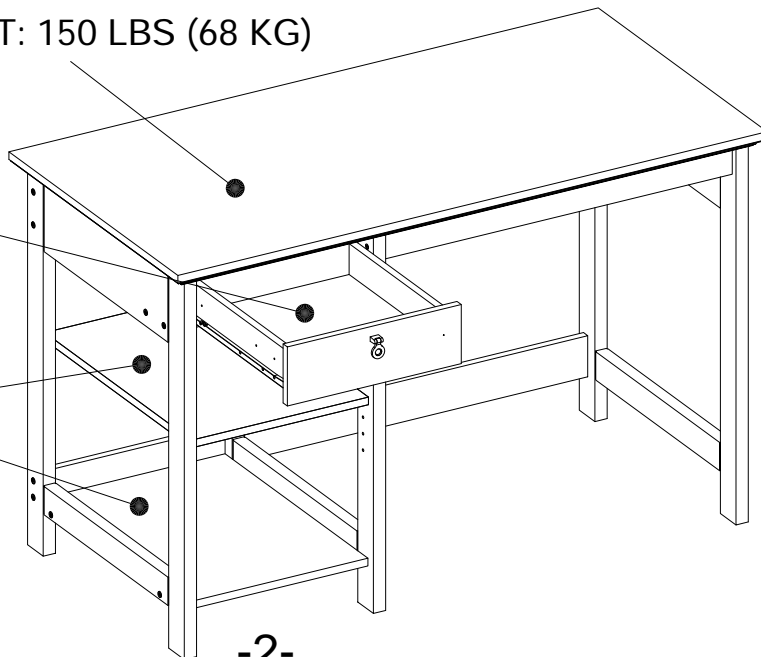

MAXIMUM WEIGHT: 150 LBS (68 KG)

MAXIMUM WEIGHT:
11 LBS (5 KG)

MAXIMUM WEIGHT:
22 LBS (10 KG)

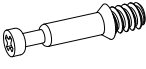

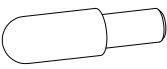
HARDWARE LIST

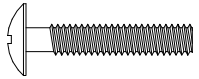
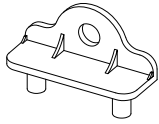
Name	Part	Qty.	Spare
A		11	1
B		11	1
C		18	1
D		4	
F		1	
G	 7/8" Bolt	1	1
H		2	

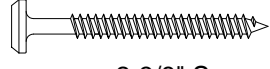
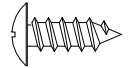
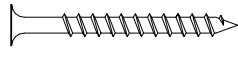
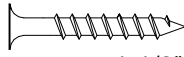
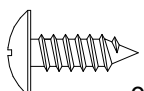
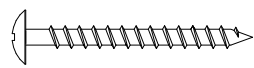
Name	Part	Qty.	Spare
I	 2-3/8" Screw	18	1
J	 1/2" Screw	4	
K	 2" Screw	5	1
L	 1-1/2" Screw	4	
M	 9/16" Screw	2	
O	 2" Screw	2	

STEP 1

C x 9pcs



A x 2pcs

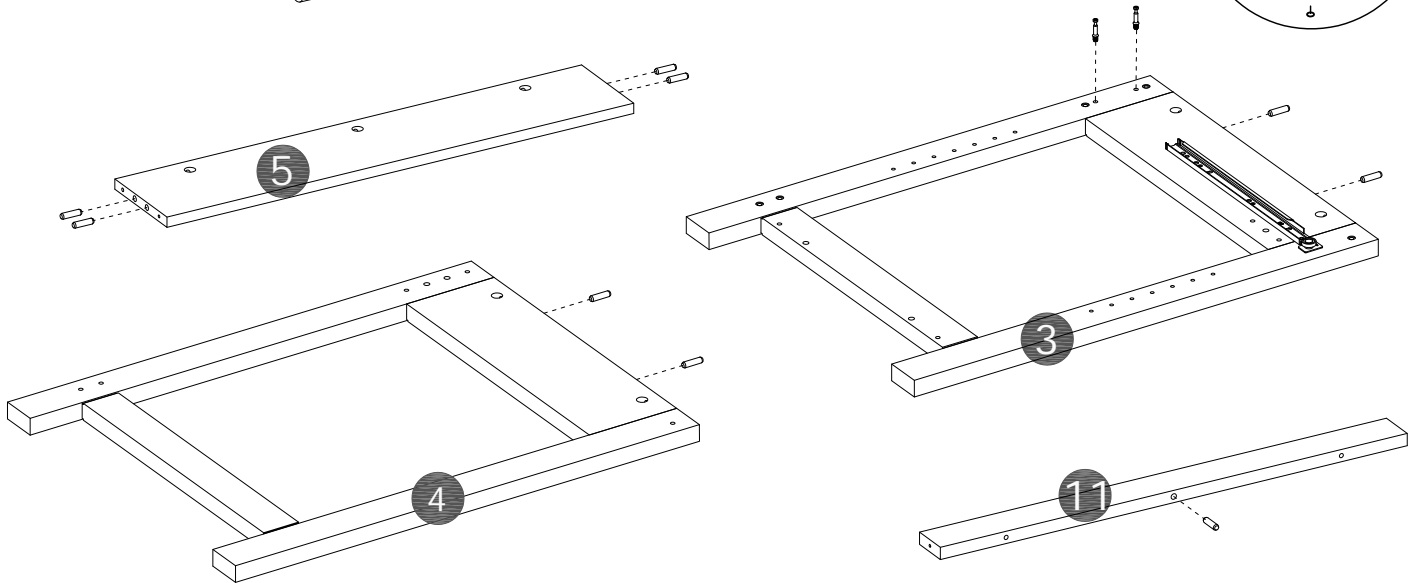
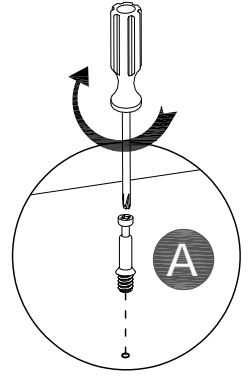
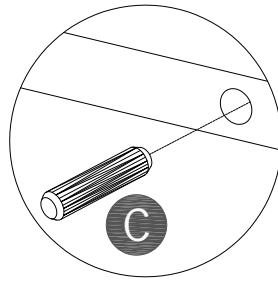
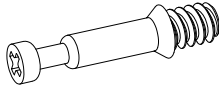

STEP 2

An assistant is required.

K x 4pcs

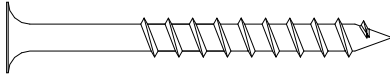

I x 4pcs

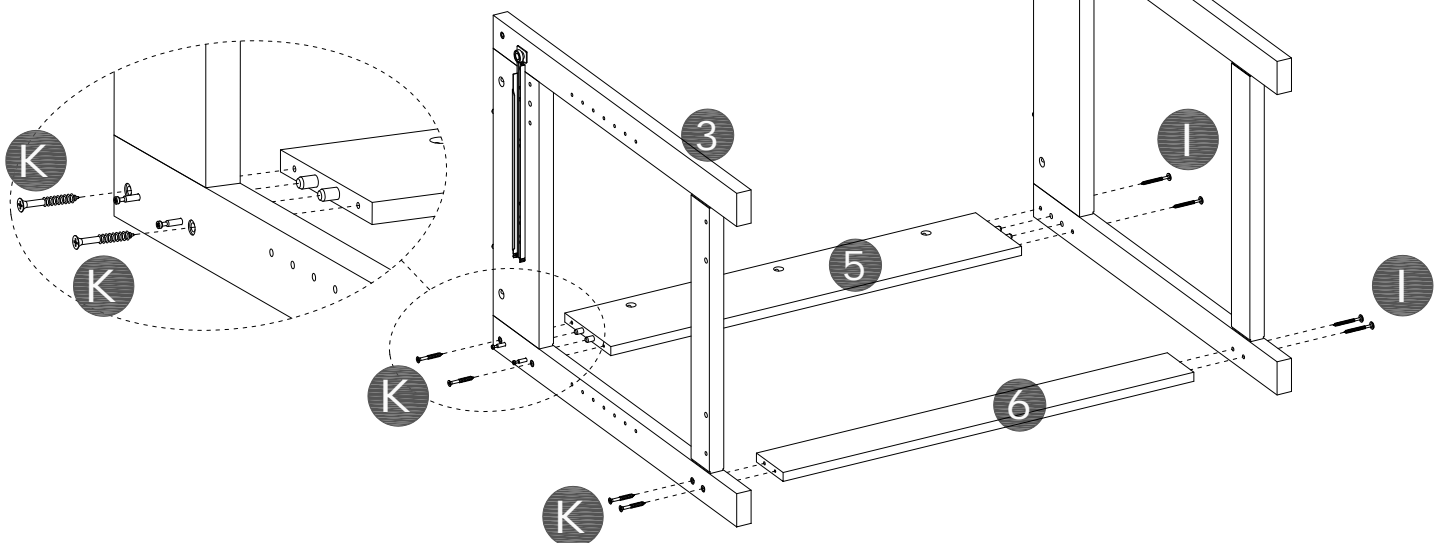
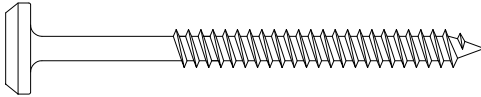

STEP 3

An assistant is required.

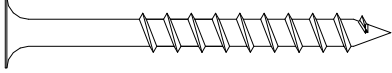
K x 1pc 

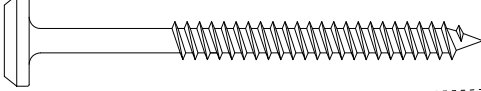
L x 1pc 

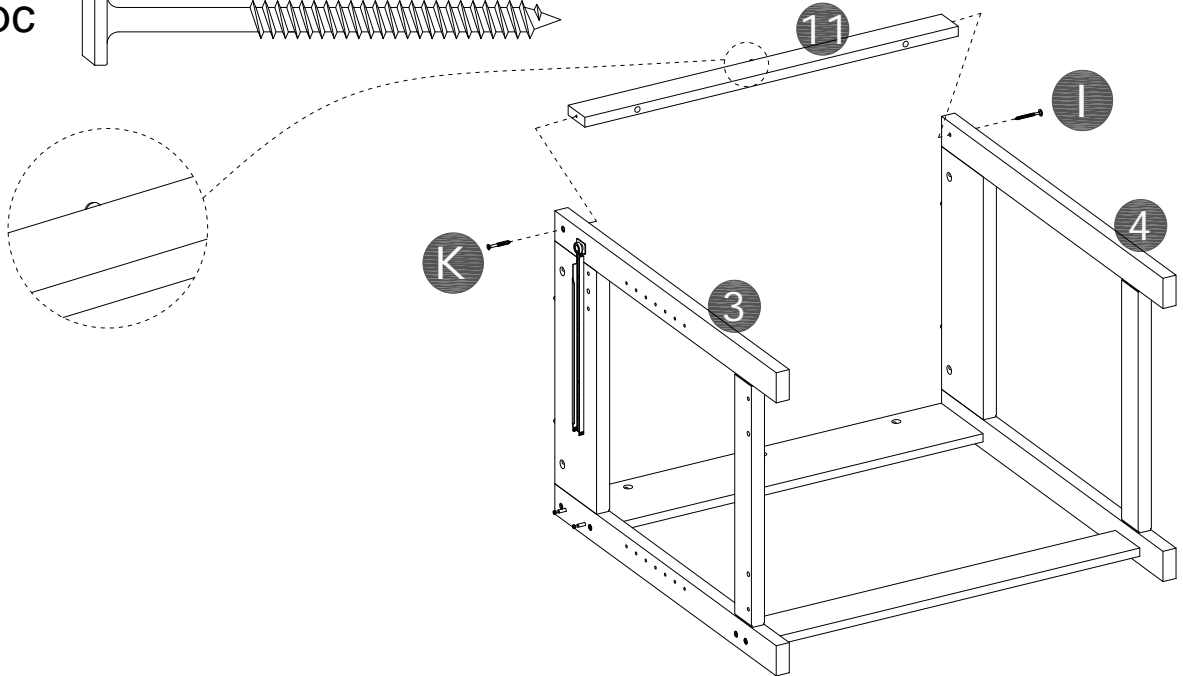

STEP 4

C x 9pcs 

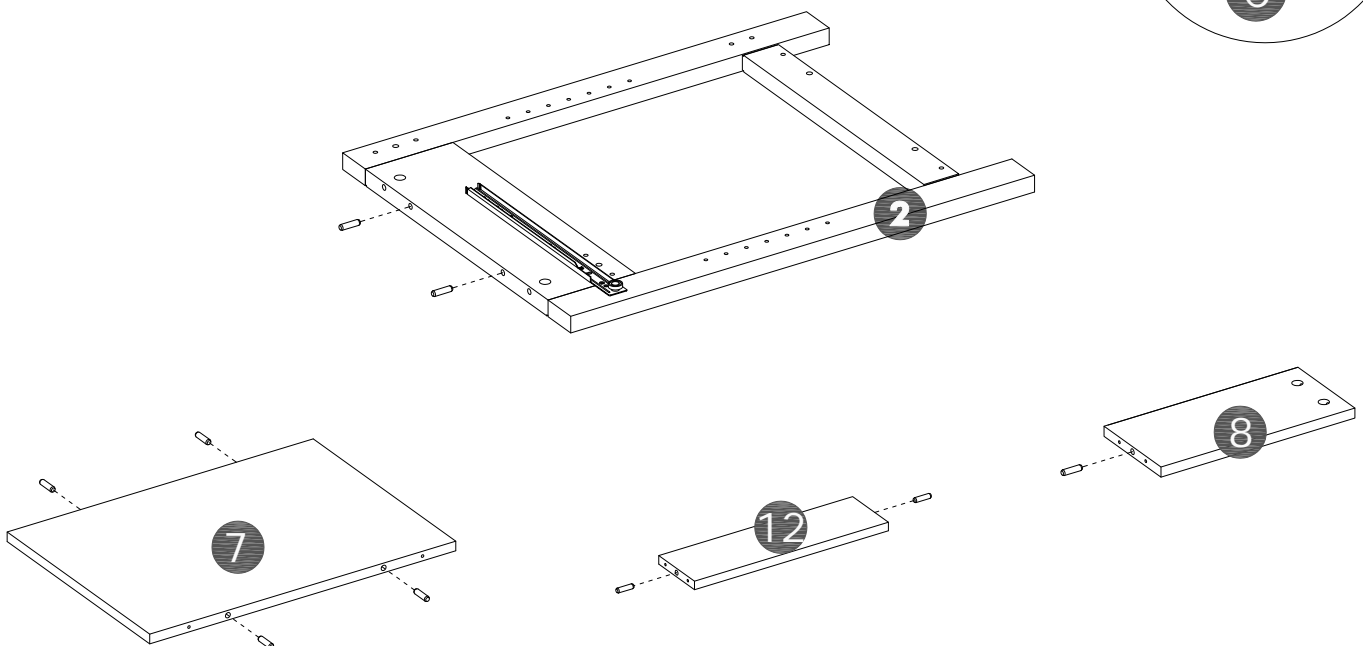
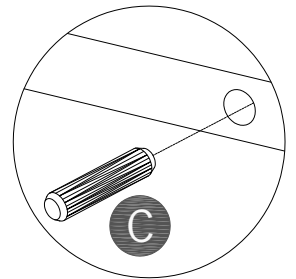

STEP 5

1 x 1pc

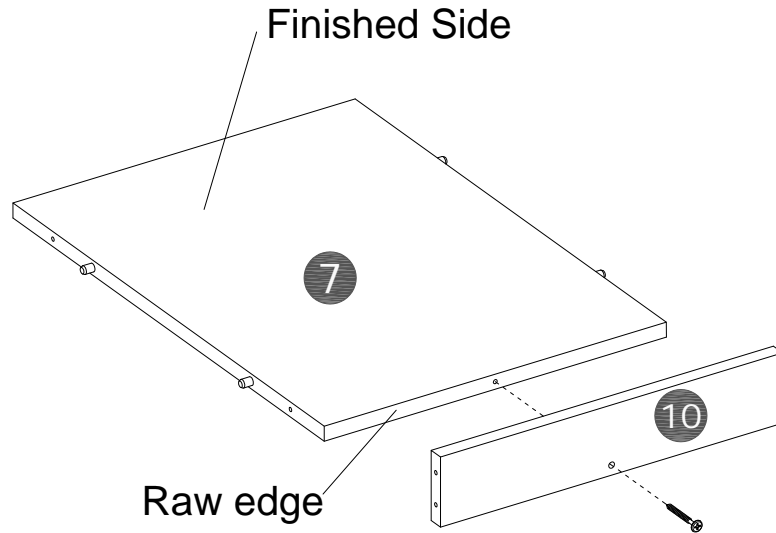
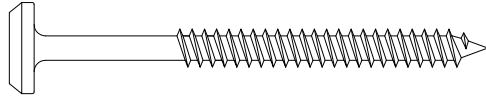

STEP 6

B x 2pcs

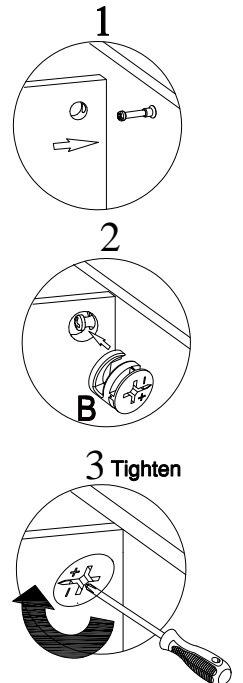
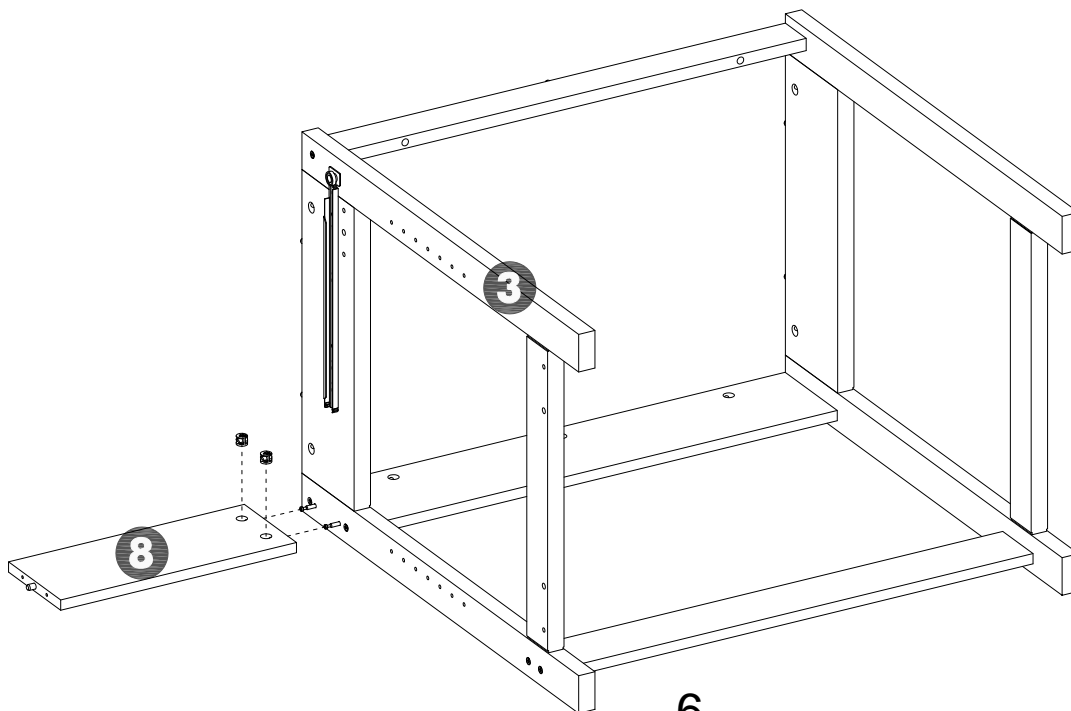

STEP 7

1 x 4pcs

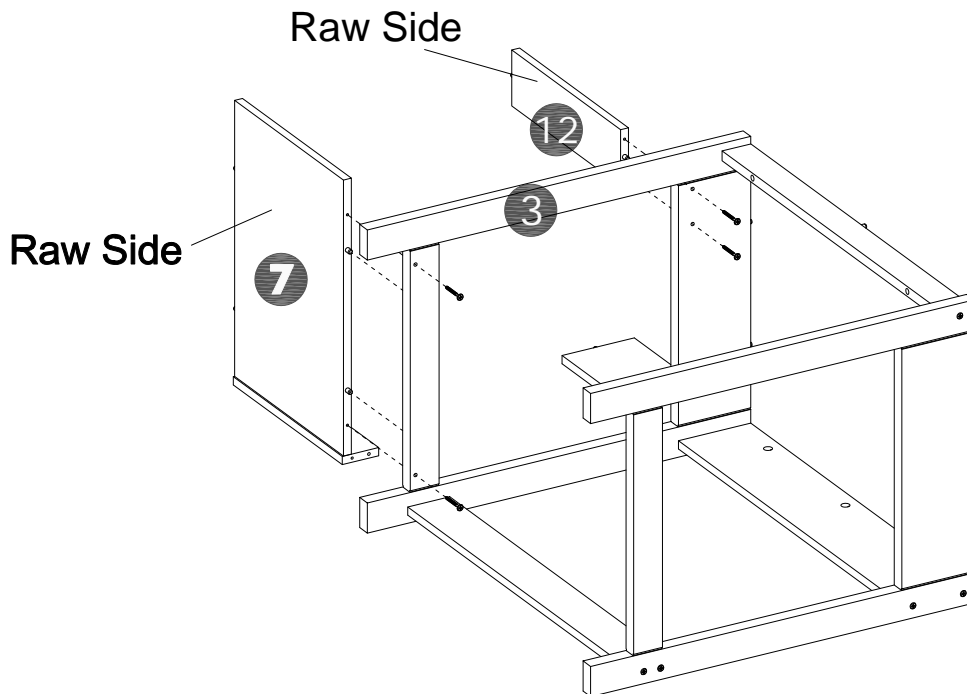
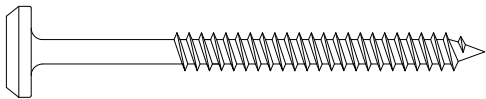

STEP 8

1 x 8pcs

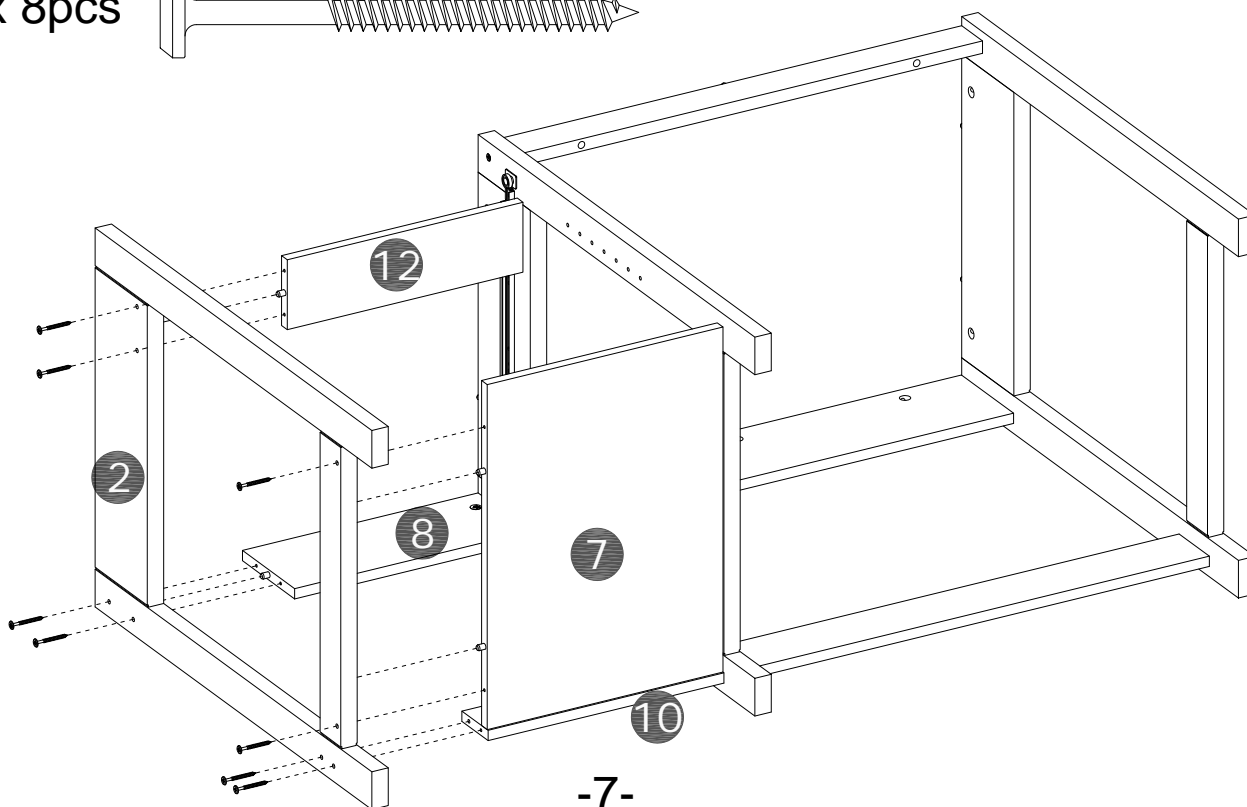
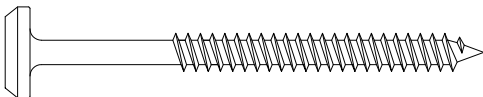

STEP 9

A x 9pcs

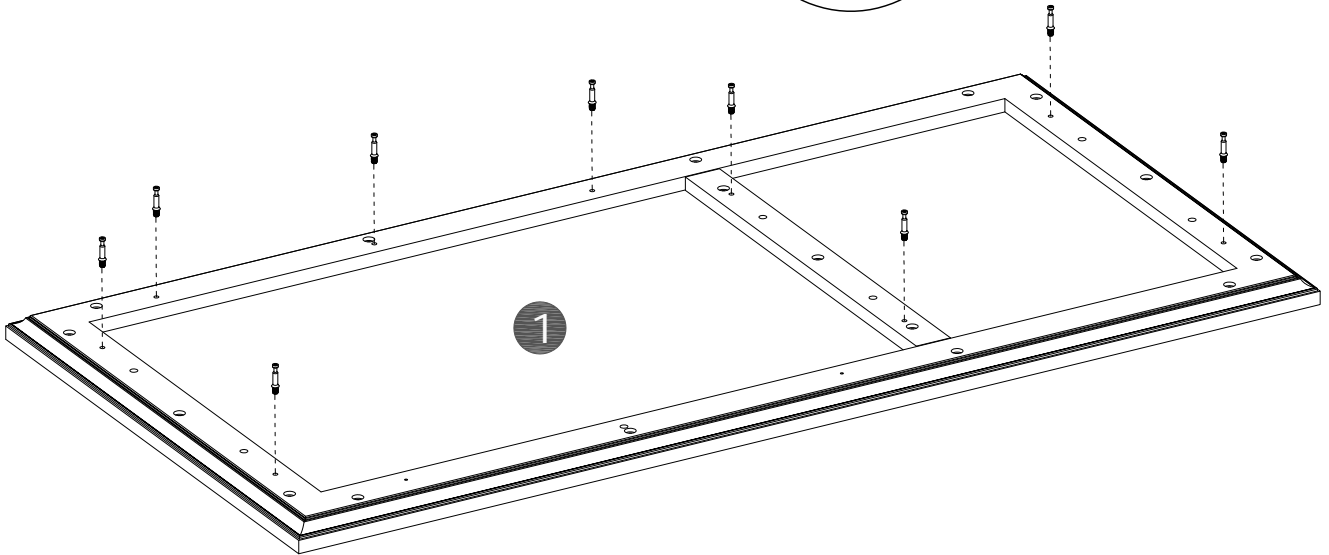
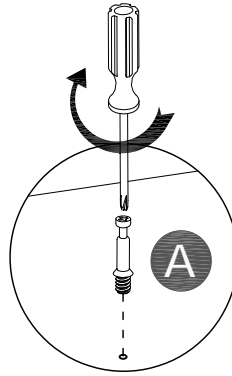
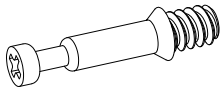

STEP 10

B x 9pcs



O x 2pcs

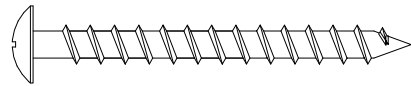

With assistant carefully stand unit up.

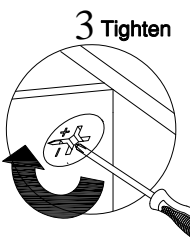
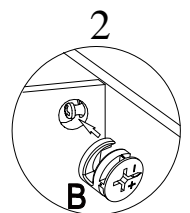
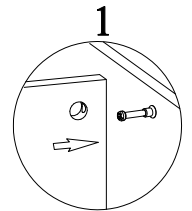
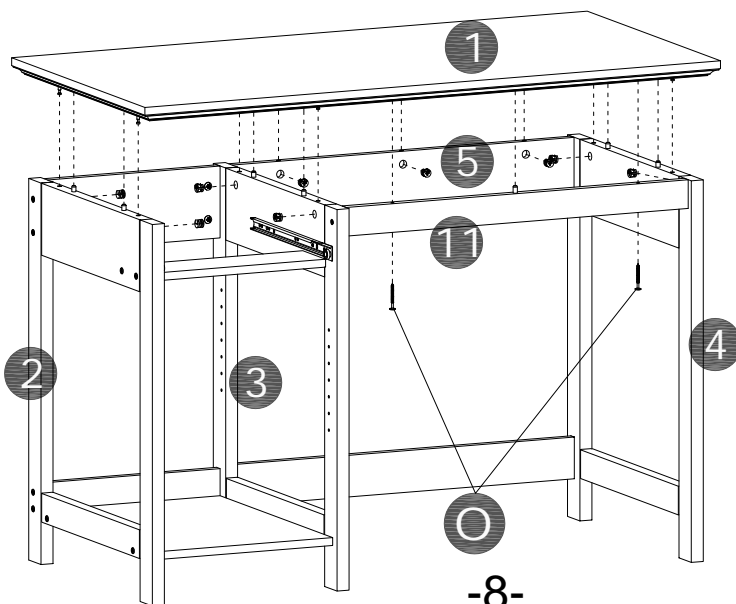

STEP 11

D x 4pcs

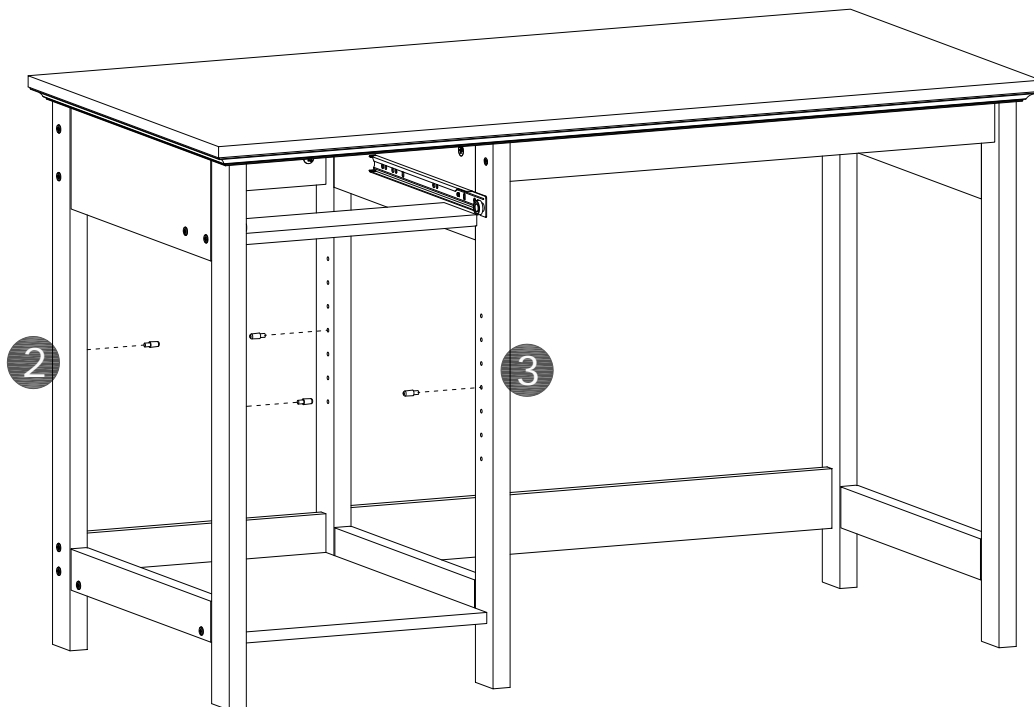
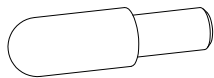

STEP 12

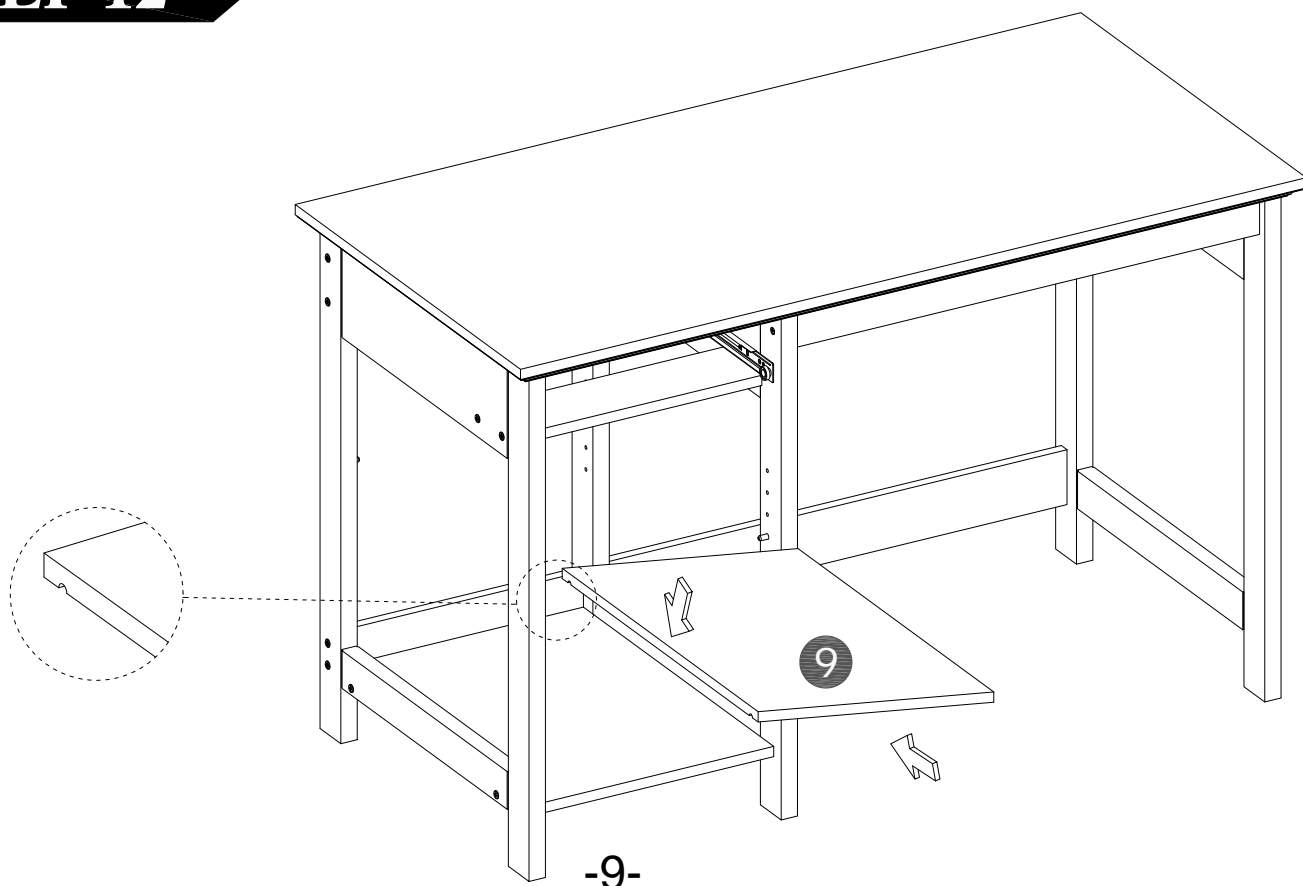

STEP 13

H x 2pcs

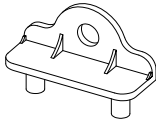

M x 2pcs

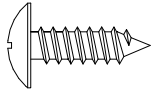

Do not use power screw driver,
use manual screw driver.

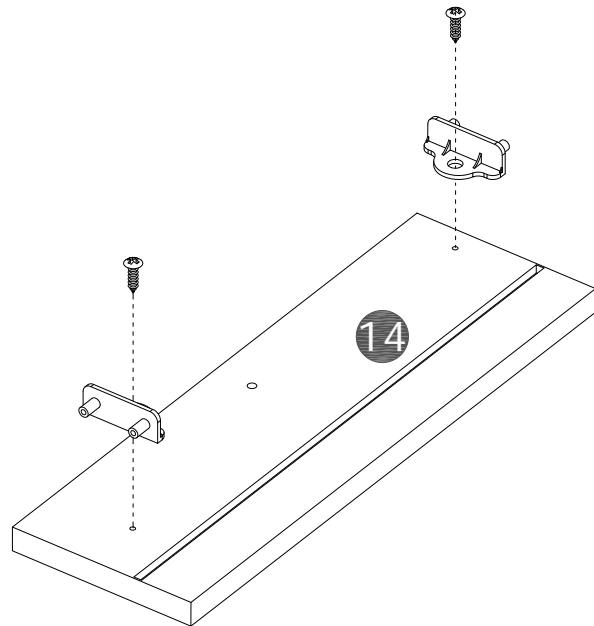

STEP 14

J x 4pcs

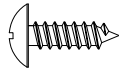

L x 4pcs

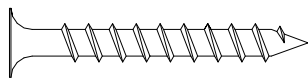

Do not use power screw driver,
use manual screw driver.

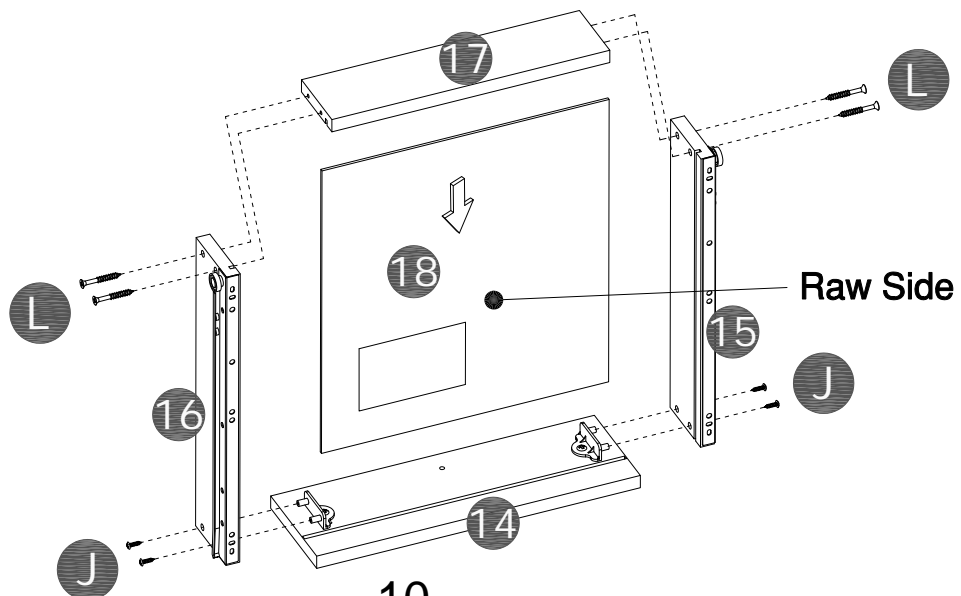

STEP 15

F x 1pc



G x 1pc

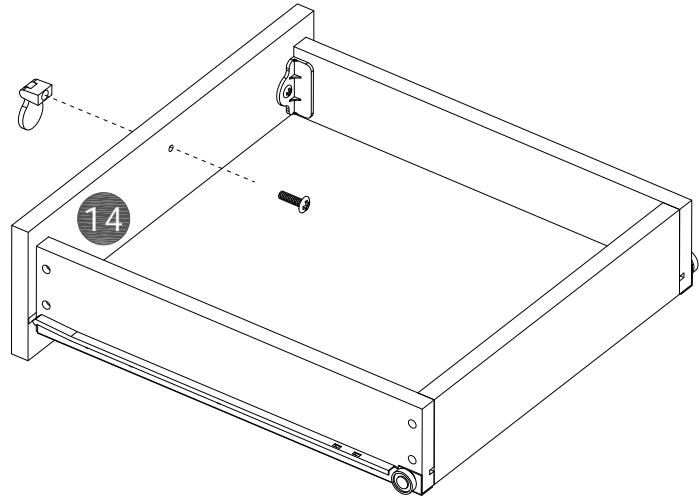
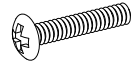

STEP 16

- Move unit to final location.
- Adjust drawer fronts as shown below.

Step1--Loosen screws on back of drawer front brackets as shown.

Step2--Position drawer front as required.

Step3--Tighten screws while holding drawer front in position.

STEP 1.

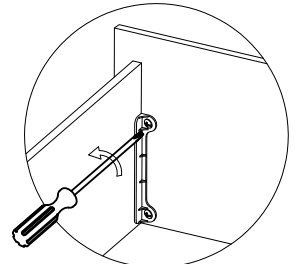

STEP 2.

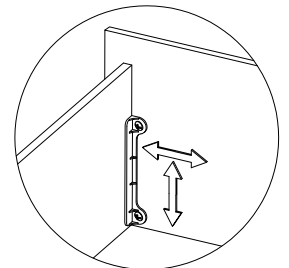

STEP 3.

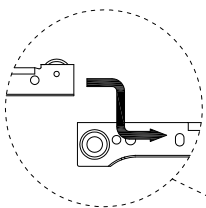
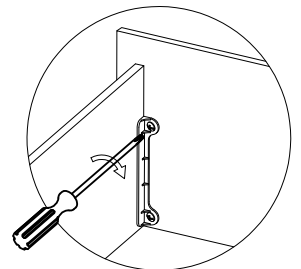

DRAWER FRONT VIEW

