

ASSEMBLY INSTRUCTIONS

MODEL :
C0332A-F48 / C0332A-YXN
FULL (4+4)

(Box 1)
BOX OF HEADBOARD & FOOTBOARD

No	ITEM	Qty
A	Headboard	1 pc
B	Footboard	1 pc
C	Headboard Leg (L)	1 pc
D	Headboard Leg (R)	1 pc
E	Bed Slats	4 pcs
F	Bed Slats Support	4 pcs
G	Headboard Bottom Stretcher	1 pc

(Box 2)
BOX OF SIDE RAIL

No	ITEM	Qty
H	Side Rail	2 pcs

(Box 1)
HARDWARE LIST

No	ITEM	Qty
1	Pan Head M4 x 32mm Blk	12 pcs
2	Csk M4 x 32mm Rbw	8 pcs
3	ALLEN KEY m5x65mm Blk	1 pc

STEP 1 : Attach Head Board Leg (C & D) to Head Board (A) as shown. using Pan Head screw (1) by using the Screw Driver (not Included).

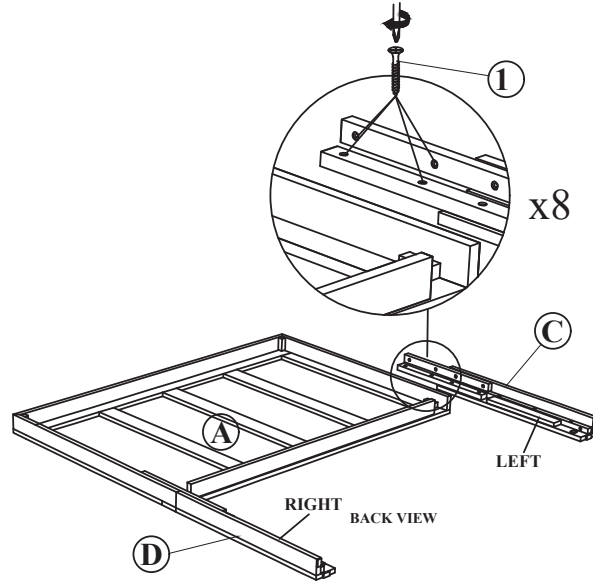

STEP 2 : Hook SIDE RAIL (H) TO HEAD BOARD (A) closely and push down to fit. repeat step 2 with other end of rail to hook onto FOOTBOARD (B).

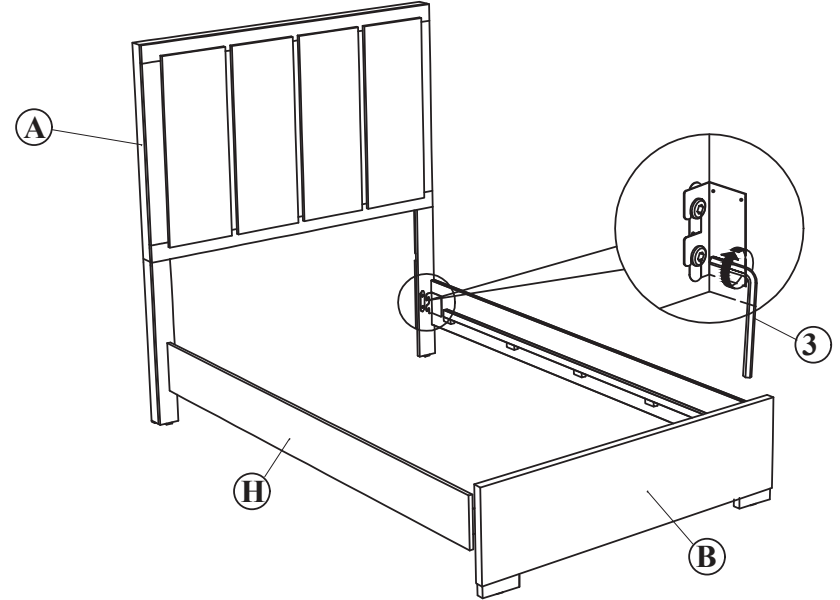

STEP 3 : Tighten the 4 Corner with Allen Key (3). Fix the Bed Slat Support (F), to Bed Slat (E) as shown. Install the bed slat (E) to side rail (H) and tighten with Csk Screw (2) as per diagram shown. (NOTE: THE SETUP MUST DONE AT THE DECIDED LOCATION FOR THE BED TO OBTAIN PERFECT STABILITY)

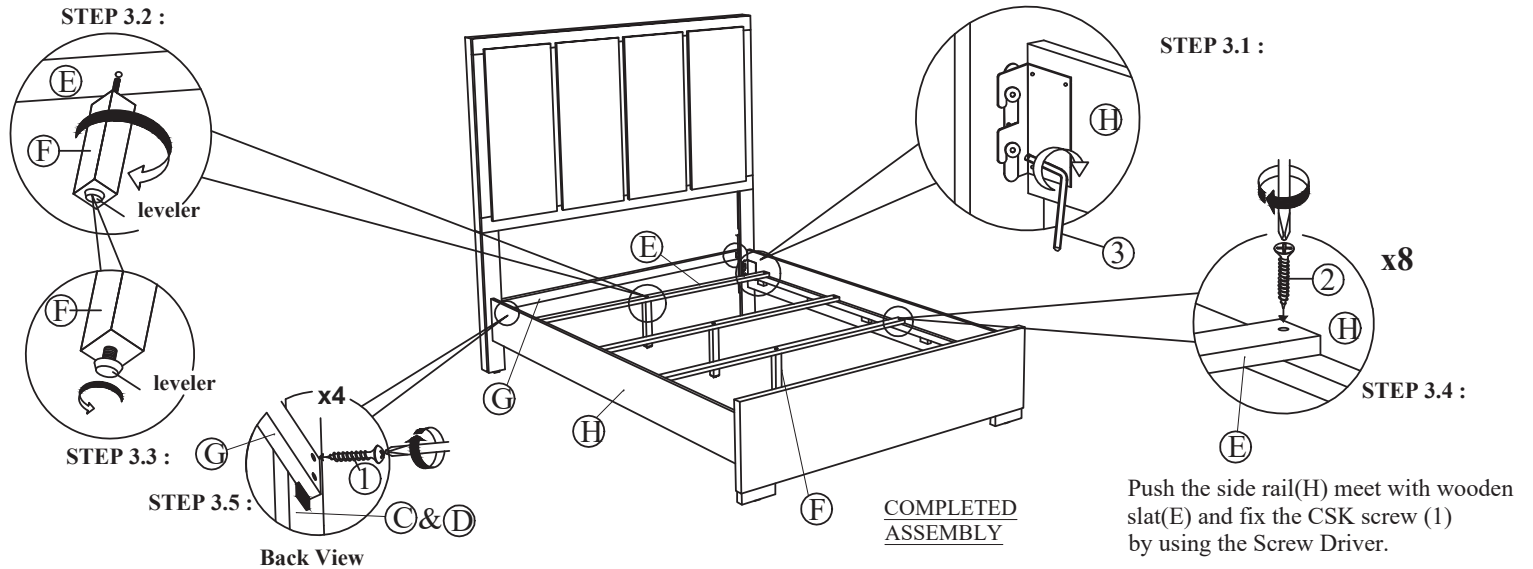

NOTE : MUST TIGHTEN SCREWS PERIODCALLY WITH USE SCREW WILL BECOME LOOSE CHECK TIGHTNESS OF ALL SCREW EVERY 6-8 WEEKS.