

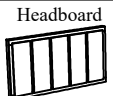

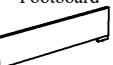

# ASSEMBLY INSTRUCTIONS

**MODEL :**  
C0332A-Q48 / C0332A-BXN  
QUEEN (4+4)

**(Box 1)**  
BOX OF HEADBOARD & FOOTBOARD

No	ITEM	Qty
A	Headboard 	1 pc
B	Footboard 	1 pc
C	Headboard Leg (L) 	1 pc
D	Headboard Leg (R) 	1 pc
E	Bed Slats 	4 pcs
F	Bed Slats Support 	4 pcs
G	Headboard Bottom Stretcher 	1 pc

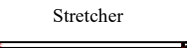
**STEP 1 :** Attach Head Board Leg ( C & D ) to Head Board ( A ) as shown. using Pan Head screw ( 1 ) by using the Screw Driver (not Included).

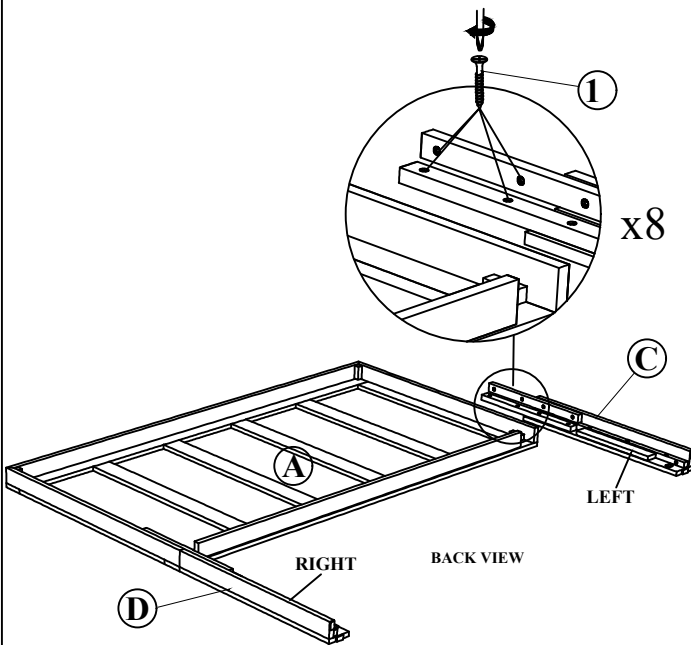

**STEP 2 :** Hook SIDE RAIL ( H ) TO HEAD BOARD ( A ) closely and push down to fit. repeat step 2 with other end of rail to hook onto FOOTBOARD ( B ).

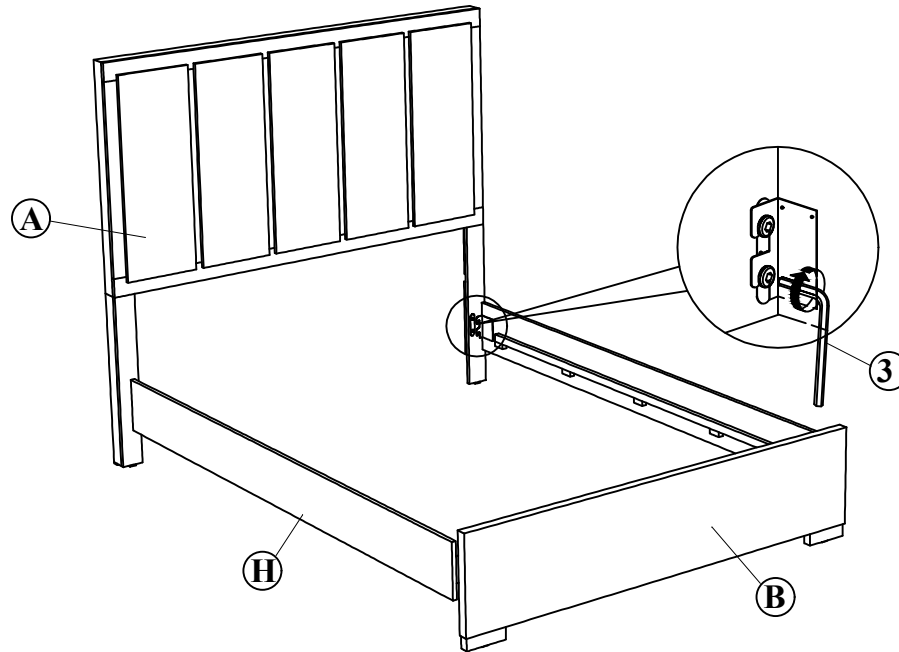

**(Box 2)**  
BOX OF SIDE RAIL

No	ITEM	Qty
H	Side Rail 	2 pcs

**(Box 1)**  
HARDWARE LIST

No	ITEM	Qty
1	Pan Head M4 x 32mm Blk 	12 pcs
2	Csk M4 x 32mm Rbw 	8 pcs
3	ALLEN KEY m5x65mm Blk 	1 pc

**STEP 3 :** Tighten the 4 Corner with Allen Key ( 3 ). Fix the Bed Slat Support ( F ), to Bed Slat ( E ) as shown . Install the bed slat ( E ) to side rail ( H ) and tighten with Csk Screw ( 2 ) as per diagram shown. (NOTE: THE SETUP MUST DONE AT THE DECIDED LOCATION FOR THE BED TO OBTAIN PERFECT STABILITY)

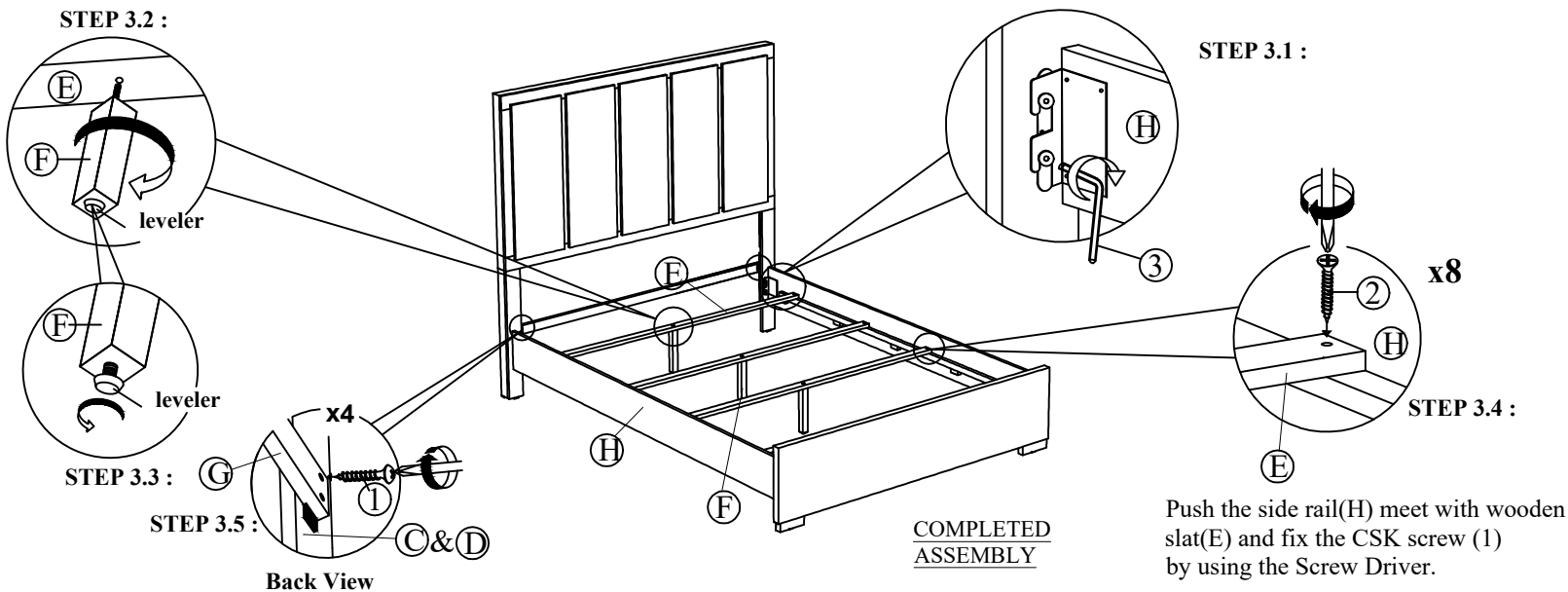

NOTE : MUST TIGHTEN SCREWS PERIODCALLY WITH USE SCREW WILL BECOME LOOSE CHECK TIGHTNESS OF ALL SCREW EVERY 6-8 WEEKS.